

PARTER

KLATKA "A"

MIESZKANIE NR 1

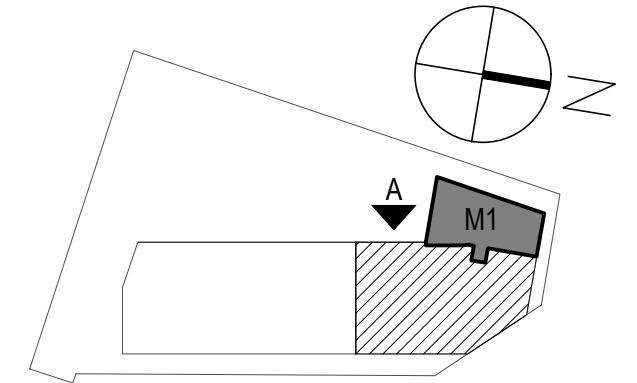
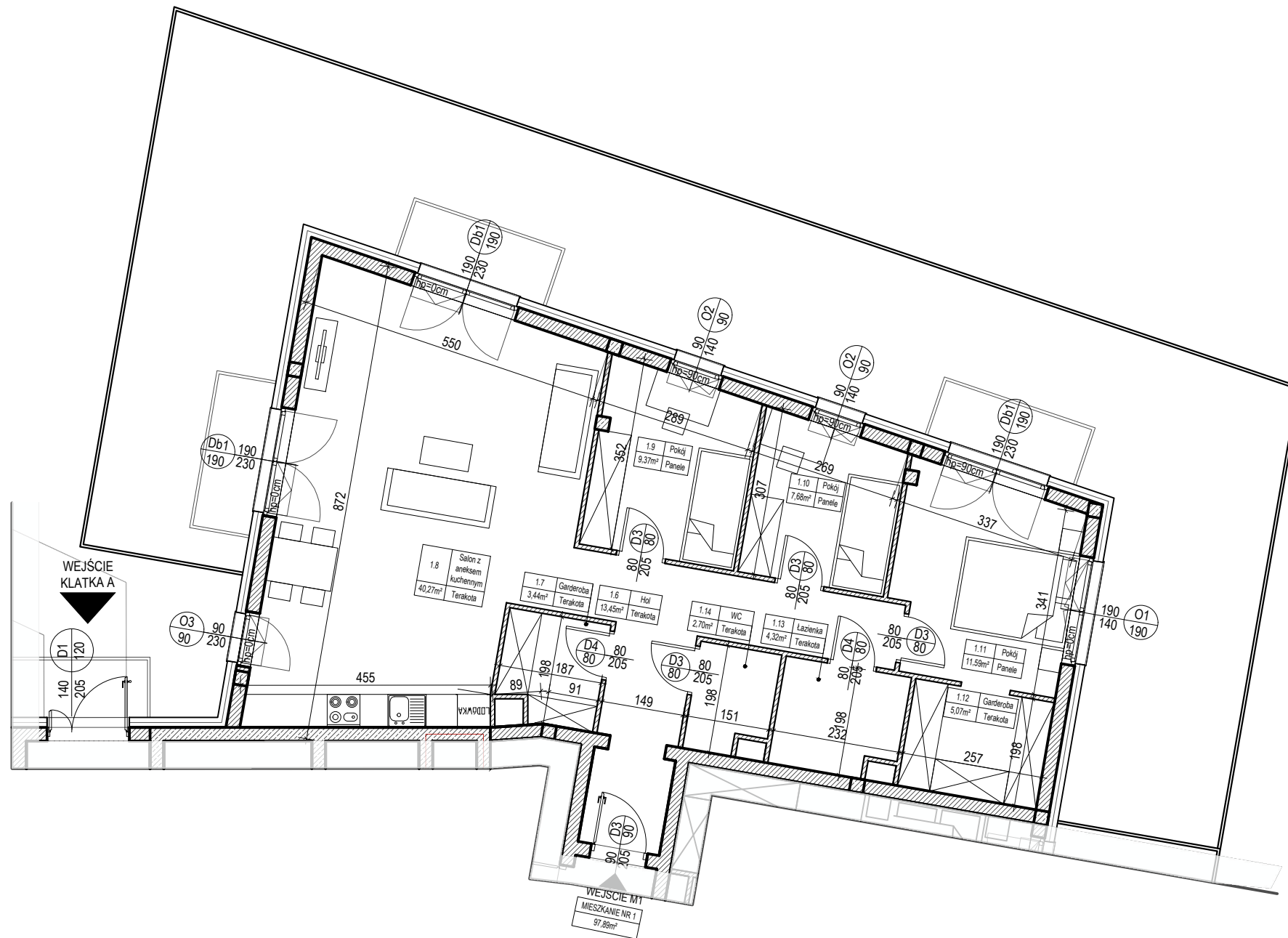

WYKAZ POWIERZCHNI - MIESZKANIE NR 1				
L.P.	NR POM.	NAZWA POMIESZCZENIA	POSADZKA	POWIERZCHNIA UŻYTKOWA [M ²]
KLATKA "A"				
1	1.6	HOL	TERAKOTA	13,45
2	1.7	GARDEROBA	TERAKOTA	3,44
3	1.8	SALON Z ANEKSEM KUCHENNYM	TERAKOTA	40,27
4	1.9	POKÓJ	PANELE	9,37
5	1.10	POKÓJ	PANELE	7,68
6	1.11	POKÓJ	PANELE	11,59
7	1.12	GARDEROBA	TERAKOTA	5,07
8	1.13	ŁAZIENKA	TERAKOTA	4,32
9	1.14	WC	TERAKOTA	2,7
RAZEM:				97,89